

# EagleClaw Grapple Saw

4 – 7t Excavator Class

5 & 7 Finger By-Pass



**FERNTREE  
EQUIPMENT  
& DISTRIBUTION**



100%



MADE IN ITALY

**Ferntree Grapple Saw Solutions  
For Excavator 3t – 30t**

# EAGLE CLAW SERIES & THUMM Rotator / Germany

## Made for the Professional user

- Forest & Logging
- Demolition
- Landscape
- Material Handling

Top Plate prepared for Rotators from

- AVS – Austria
- Thumm - Rotators Sweden
- Simple Bolt on Pattern
- No Adapters needed

### Technical details:

max. thrust load:	= 60 kN
max. radial load:	= 40 kN
p max. grab	= 35 MPa/350bar
p max. rotating engine	= 25 MPa/250bar
max. torque	= 1650 Nm
Torque / 100bar	= 660 Nm
Adsorption volume	= 520 cm <sup>3</sup> /R
min. oil passage Gs / Go	= NW 12
Mass	= 73 kg
max. rotations	= 30 rpm
Bending moment Mb per.	= 6,1 kNm (leaf 4.606.00)



\*Ferntree holds the right for technical changes at any time

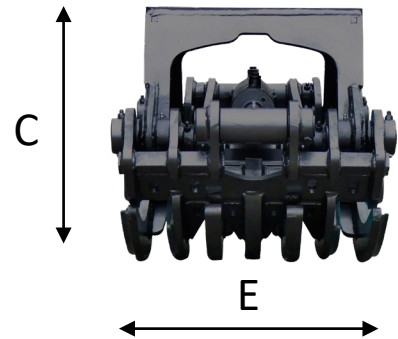
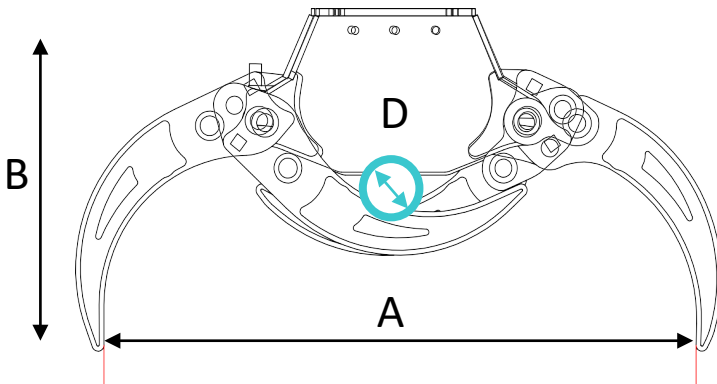

MODEL	5 finger lbs	7 finger lbs	Excavator class	A	B	C	D	E
UNI 1.1	210	225	1.5-3t	38"	24.7"	17"	1"	16.8"
UNI 1.2	480	525	3 -7t	48"	26.7"	20"	2.25"	18.8"
UNI 1.5	830	870	7 – 12t	60"	32.7	23.6"	3"	20.8"
UNI 1.7	1170	1205	12 – 20t	68"	37"	27"	3.5"	22.8"

**FERNTREE EQUIPMENT Import & Distribution for North-America**

Info@ferntree.ca +1 778 222 9111 Guelph Ontario Canada www.ferntree.ca

# EAGLE CLAW SERIES

## Chainsaw Kit IT450CTH



\*Ferntree holds the right for technical changes at any time

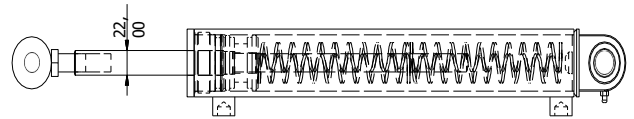
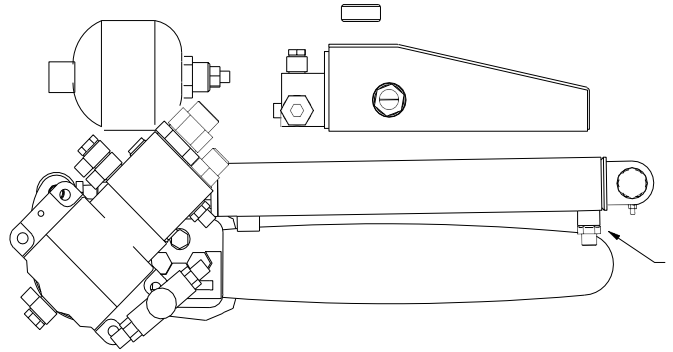

Bar – return through Spring loaded Cylinder

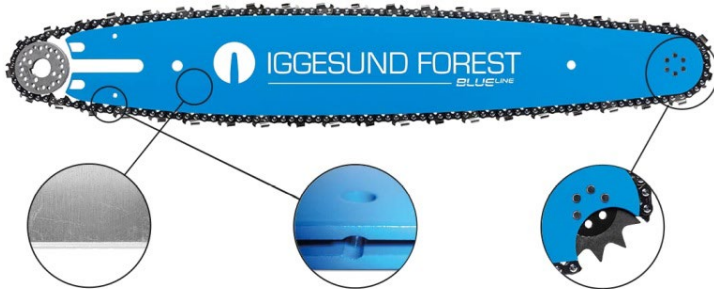
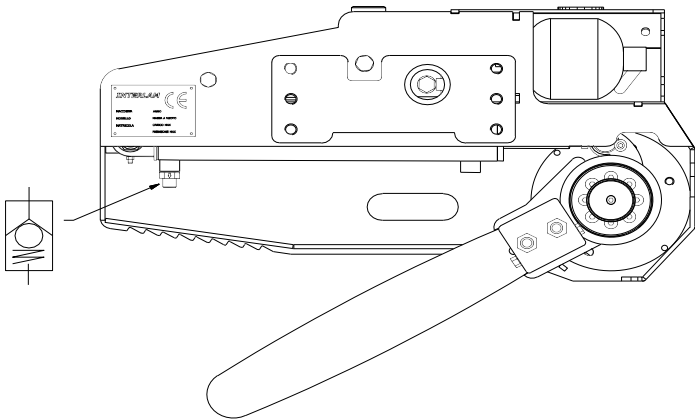

IT 450 CTH	Interlam Saw Box
Flow	Min 12gpm – Max 16gpm
Pressure	250bar / 3625 psi
Motor	Parker F11-06 Case Drain direct to Tank with max 20psi return pressure
Cut Capacity	17" Standard or 20" OREGON, IGGESUND, WARTH etc
Sprocket	B 11
Chain	404 – 1.6
Oil Tank	1.5L / 0.4 Gallon
Tension	Mechanical

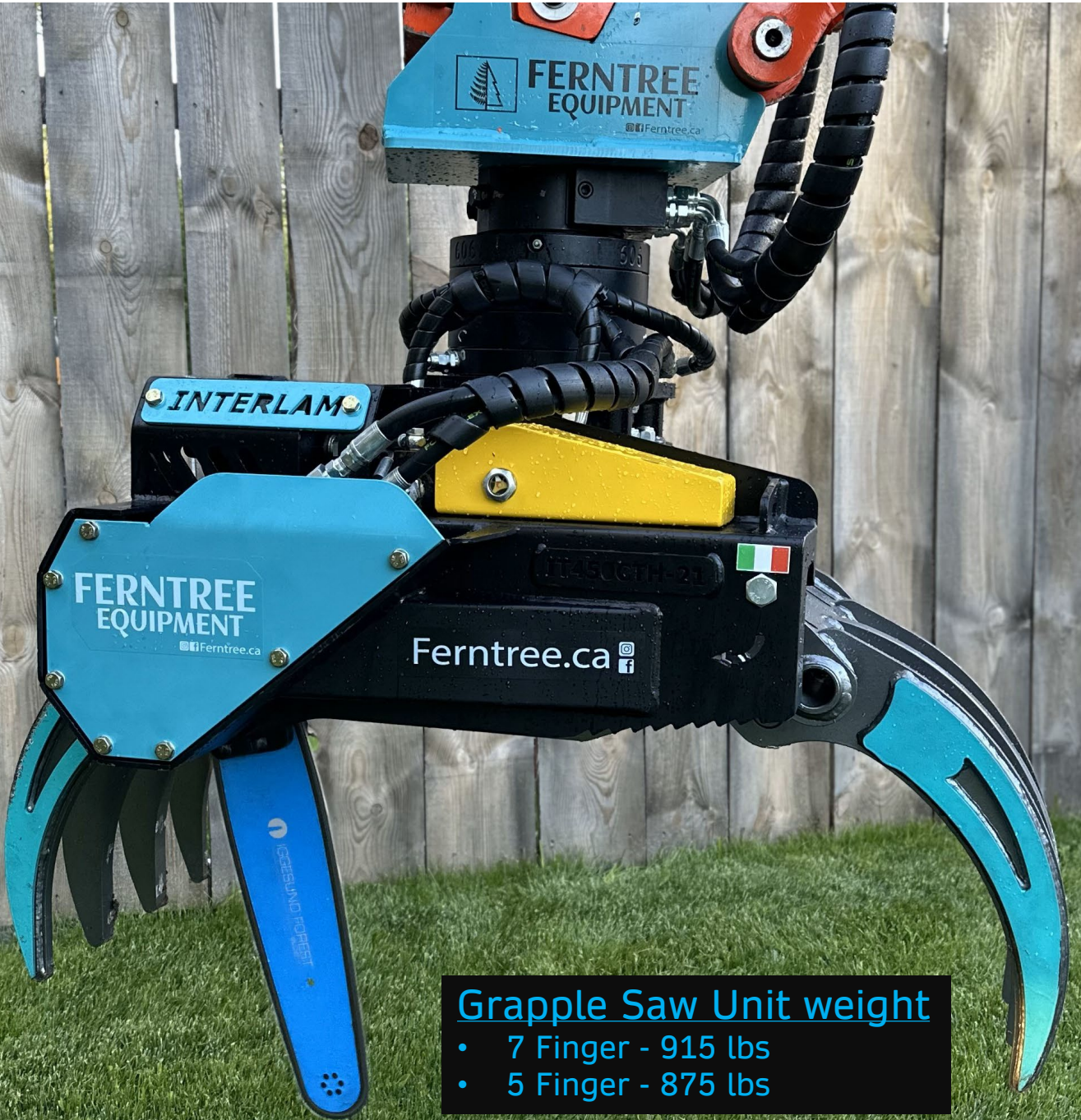

**Grapple Saw Unit weight**

- 7 Finger - 915 lbs
- 5 Finger - 875 lbs

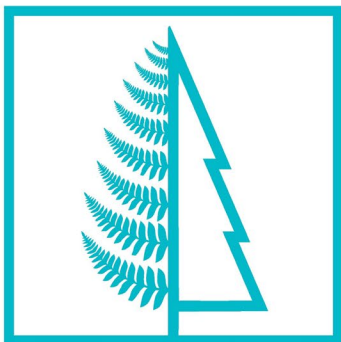

**FERNTREE  
EQUIPMENT**