

IT1900.3/4 Grapple Saw
18-25t Excavator Class
7 Finger By-Pass
Worm Drive- Rotator



**FERNTREE
EQUIPMENT
& DISTRIBUTION**
YOUR QUALITY BRAND CONNECTION



www.ferntree.ca

100%



MADE IN ITALY

**Ferntree Grapple Saw Solutions
For Excavator 3t - 30t**

INTERLAM SERIES IT1900 - 3/4 SAW KIT

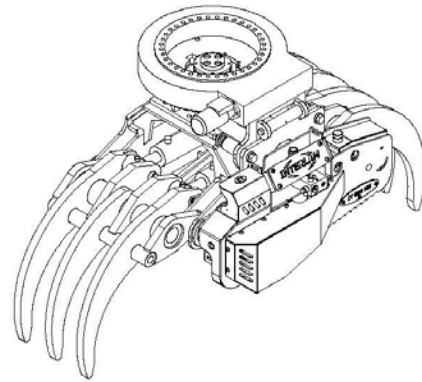
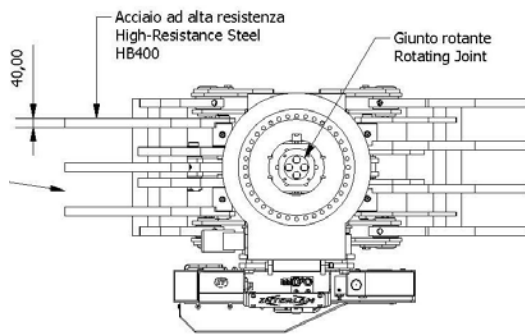
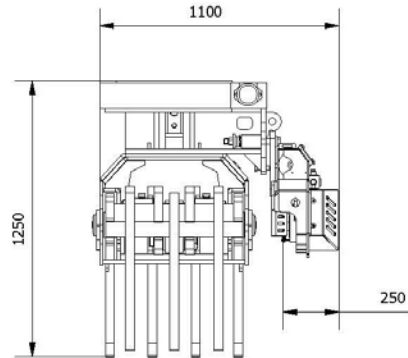
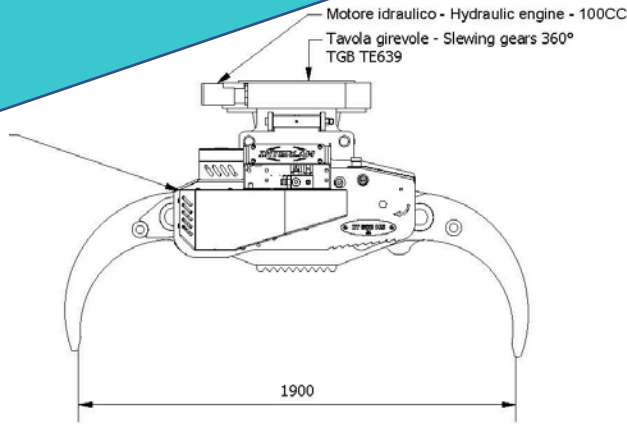

*Ferntree holds the right for technical changes at any time

IT 3/4 CTH	Interlam Saw Box
Flow	Min 31 – 42 Gpm
Pressure	250bar / 3625 psi
Motor	Parker F12 / 30 Case Drain direct to Tank with max 20psi return pressure
Cut Capacity	36" Standard or 40" OREGON, IGGESUND, Wartah etc
Sprocket	V9 3/4 D30
Chain	3 / 4
Oil Tank	1.5L / 0.4 Gallon
Tension	Mechanical or Optional Automatic

INTERLAM SERIES IT1900 - 3/4 SAW KIT

Made for the Professional user

- Forest & Logging
- Demolition
- Landscape
- Material Handling
- Hardox build body and claw
- Modular build with saw box 3/4 CTH



Approximately
3900-4000Lbs incl. Pin Grab
as per Excavator Specs

IT 1600 C2 - IT 1900 C2



3590 Lbs
Base unit



					Portata Kg Load Kg	Bar max	Peso Kg Weight Kg	Excavator ton	
IT 1600 C2	110	600	700	1.600	5,000	250	430	9 - 16	IT 700 CTH IT 800 MS IT 800 MSA
IT 1900 C2	110	720	1.100	1.900	8,000	250	800	18 - 25	IT 3-4 MS IT 3-4 SC



The IT 1600 & 1900 C2 log grab was designed for heavy-duty work. The open forks made of 40 mm thick STEEL HB 400 and the two hydraulic cylinders allow easy handling of logs and branches. The clamp can be equipped with a 3/4" chainsaw kit and slewing ring rotation.



*Ferntree holds the right for technical changes at any time

INTERLAM SERIES IT1900 - 3/4 SAW KIT

**FERNTREE
EQUIPMENT
& DISTRIBUTION**
YOUR QUALITY BRAND CONNECTION



IT 1050.350CTH



IT 1900.3/4 MS



**FERNTREE
EQUIPMENT
& DISTRIBUTION**
YOUR QUALITY BRAND CONNECTION

**Import & Distribution
North-America**
Info@ferntree.ca
+1 778 222 9111
Guelph Ontario Canada
www.ferntree.ca